



Description

HCS DataRack series includes a wide range of high quality racks, cabinets and enclosures, specially designed for structured premise cabling in local area networks (LANs), including distribution and equipment, cross connect cabinets and racks, splice boxes, climate control and many more components for both copper and fiber optic cabling systems.

HCS DataRack 27 600x450 Wall Mount Cabinets are suitable mainly for office environments & equipment rooms, having an attractive design combined with a long-lasting, solid & stable construction, guaranteed by the HCS DataRack Logo & Trademark.

Applications

The special design of HCS DataRack 27 Wall Mount Cabinets allows the use of a large variety and types of accessories, including 19" panels, hubs and active equipment, fixed and/or sliding shelves, fan units, power strips, pulleys, grounding and potential equalization bus bars, lighting units, stacking kits, floor fixing kits, cable management panels, and many other 19" devices and accessories.

Qualifications and Approvals

HCS DataLine Wall Mount Cabinets are supported by HCS DoubleSafe™ QA Program.



Benefits & Features

- Solid and stable construction- providing support for large loads.
- Aesthetic & attractive design - for use in open office environments.
- Flat packed design option- providing minimal storage space and saving transportation costs.
- Large cable spaces - enabling easy and comfortable installation of many cables.
- Sophisticated cable channeling - enabling concealed cords routing.
- Clear u-marking inside the cabinets - enabling easy & simple profile installation planning.
- Removable side, front and rear doors - allows using cabinet as a relay rack.
- Adjustable profile positioning inside the cabinets - enabling efficient installation of different size devices.
- Vented top cover- allows passive ventilation.
- PVC stoppers - avoid metal surface noise while side panels are mounted.
- Pulleys and levelling fit mountable - enabling installation as free-standing cabinets.

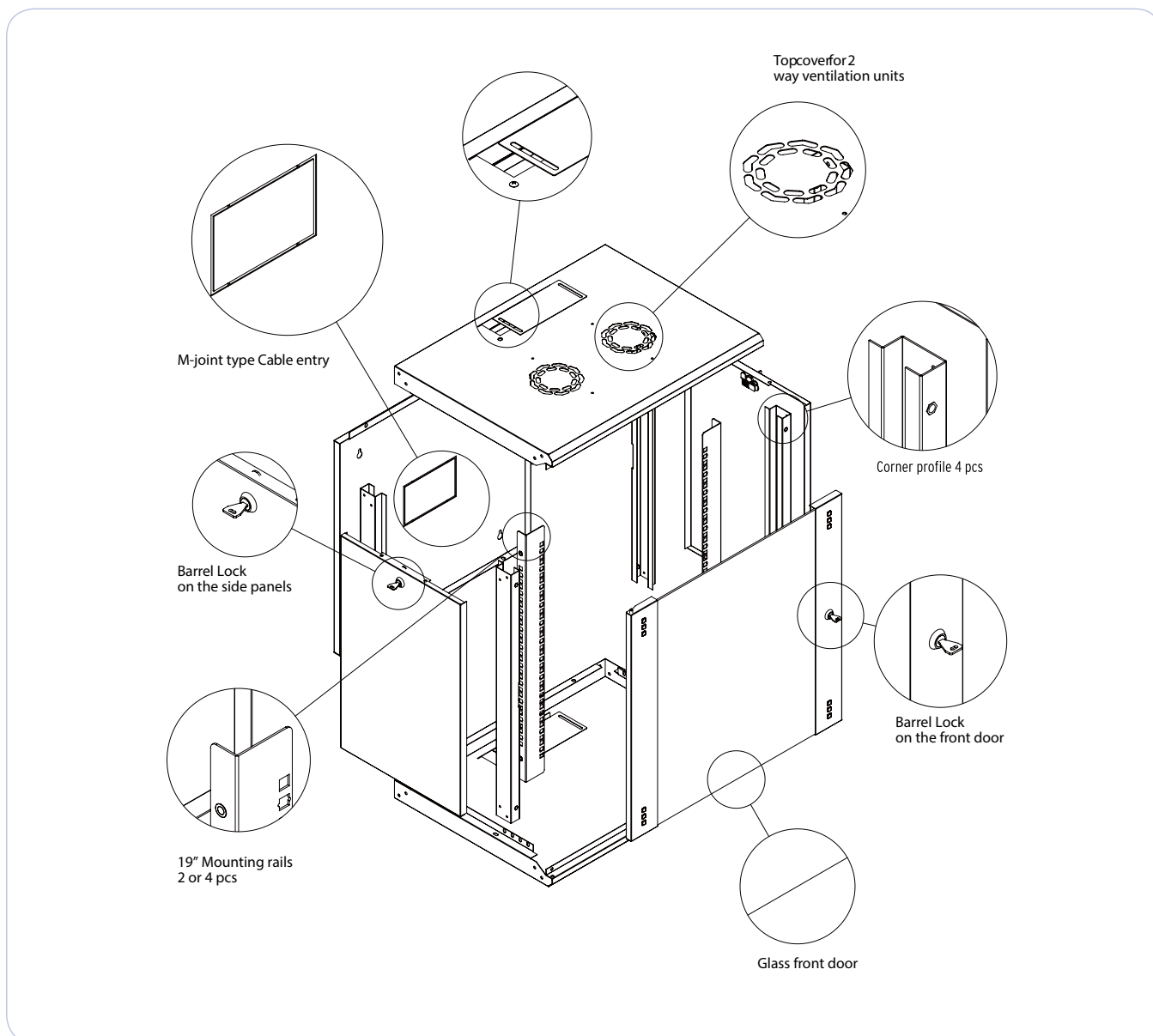

GENERAL PROPERTIES

Material of Construction	Sheet & Galvanized steel. 1.0/1.2/1.5mm thickness.
Paint and Color	Special steel finish with electrostatic powder coat, RAL 7035 grey. Other colors available upon request.
Front Door	Smoked, secured and tempered glass, 4 mm. thick, reinforced with metal frame. Interchangeable (Left&right). 180 degree opening for single use.
Side Panels	Removable, complete metal. Single point cylindrical locking mechanism.
Rear Panel	Removable, complete metal. Mounting plate supported with welding. 100x150 mm M-joint cable entry hole.
Top Chassis	Monoblock, welded. Fan tray mountable. 50x150 mm sliding cable entry hole.
Bottom Chassis	Monoblock, welded. 50x150 mm sliding cable entry hole.
19" profiles	Adjustable, 2 units in the front. U-marked.
Vertical Cable Organizer	None.
Front Door Lock	Single point cylindrical locking mechanism.
Levelling fit & Pulleys	Optional.
Loading Capacity	100 kg max.

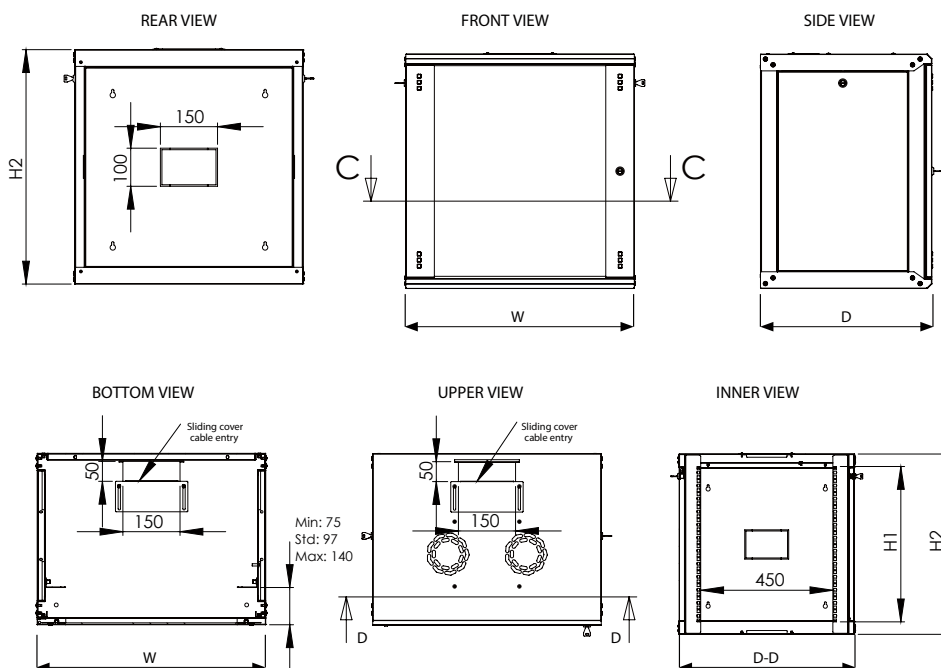

ORDERING INFORMARTION

HCS P/N	Descriptions	Internal Height mm	Dimensions			Net Weight Kg	Notes
			Width mm	Depth mm	Height mm		
C27-00464	4U 19" Wall Mount Cabinet	177,8	600	450	259,75		
C27-00764	7U 19" Wall Mount Cabinet	311,15	600	450	393,1	17	
C27-00964	9U 19" Wall Mount Cabinet	400,05	600	450	482	20	
C27-01264	12U 19" Wall Mount Cabinet	533,4	600	450	615,35	23	
C27-01664	16U 19" Wall Mount Cabinet	711,2	600	450	793,15	27	
C27-02064	20U 19" Wall Mount Cabinet	889	600	450	970,95	33	